

eDAQ™ Type 8102C

Real Time Process Monitoring

Real Time Process Control

High Speed Ethernet Data Acquisition



Description

The eDAQ™ system is a universal data acquisition unit for charge, temperature and voltage signals. A/D conversion of the maximum 16 measuring signals is made inside the unit itself. Additional A/D boards in the connected PC or Laptop are not necessary anymore.

Up to 8 units can be operated and synchronized simultaneously which permits the measurement of maximum 128 channels.

The unit provides a number of real time process monitoring features which can be directed as single or common signals to the respective controlling outputs. In addition the system provides controlling outputs for the automatic control of sequential molding applications as well as for the universal real time control of valves (e.g. for LSR, gas pressure or venting of mold cavities).

The unit can be operated stand-alone for process control and monitoring. Permanent Interfacing to a PC is not necessary.

However the measuring data can be transmitted digital with a high sampling rate to any kind of PC* or Laptop* via Ethernet interface (RJ45) or analog as voltage signals.

Also via Ethernet interface a webbrowser can be downloaded by using the internet browser. All general parameters and functions of the device as well as for process monitoring and control can be set up by the webbrowser.

The eDAQ™ system detects all PRIASED™ and PRIASAFE™ sensors and their sensitivities automatically. All pressure ranges are set automatically according to the measuring signals in order to achieve the highest signal resolution possible („Autoscale“-Function).

Within the scope of delivery is a so called “Master Key” which automatically determines the monitoring limits in production by simply plugging in. Individual settings of the monitoring limits are always possible by using the webbrowser.

- Universal Data Acquisition
- Integrated A/D-conversion
- Charge
- Temperature
- Voltage
- Maximum 128 channels
- Real Time Process Monitoring
- Automatic Sequential Control
- Automatic control of valves
- Stand-Alone operation
- High sampling rate
- Data transmission to any PC
- Webbrowser Setup
- Automatic sensitivity detection
- Autoscale Function
- Automatic Monitoring Limits

* Minimum specifications on request



The concept of the eDAQ™ system was designed in order to acquire and monitor measuring signals with lowest complexity and without complicated settings. At the same time the webbrowser provides numerous setup options in order to use the variety of the possible functions accordingly.

eDAQ™ is the basic unit for all PRIAMUS control systems. Due to the integrated A/D conversion extreme compact (“ultra slim”) PC solutions can be used. The eDAQ™ system itself is an embedded system which – opposite to PC based operating systems – provides extreme safe and fast switching operations for process monitoring and control.

This device is conforming to CE according to the EC directive 89/336/EWG and relates with the following standards for industrial devices: EMC emission EN50081-1 and EMC immunity EN50082-2

- Color coding if cables and connectors
- Basic unit for all PRIAMUS control systems
- „Ultra Slim“ PC solutions
- CE certified

Technical Data

Main Board			
Supply		VDC	10 ... 34
Supply proximity switch (Trigger)		VDC	10 ... 34
		mA	max. 20
Operating temperature range		°C	0 ... 60
Degree of protection		IP	54
Weight (all modules installed)			
Energy consumption (all modules installed, 24 VDC Supply)		mA	< 500
Energy demand (all modules installed)			mW
Digital Outputs			
Integrated recovery diodes for relais control on all outputs			
Maximum switching current		mA	100
Maximaler switching current, peak 1 ms duration		mA	200
Maximum operating voltage		V	40
Switching time		µs	< 100
Digital Inputs			
Trigger	Reset	V	0 ... 0.8
	Operate	V	2.4 ... 40
Encor			
Min. Input differential		mV	350
Max. Input		V	5



Temperature Measurement

Number of temperature channels (extendable in pairs of 2)			2 ... 16
Temperature sensor		Type	N (J, K)
Potential separation of measuring element (not galv. isolated)		V_{max}	± 50
Output signal		digital	14 bit
Zero voltage (0°C)		V	2
Sensitivity	0...200°C	mV/K	40
	0...400°C	mV/K	20
Accuracy		°C	2 ($\pm 1\%$)
Frequency range		Hz	0 ... 1000

Pressure Measurement

Number of pressure channels (extendable in pairs of 2)			2 ... 16
Output signal		digital	14 bit
Zero voltage (0 Bar, rel.)		V	0
Sensitivity	sensor not detected		
	2000pC/10V	mV/pC	± 5
	5000pC/10V	mV/pC	± 2
	10000pC/10V	mV/pC	± 1
	20000pC/10V	mV/pC	± 0.5
	sensor detected		
	200bar/10V	mV/bar	± 50
	500bar/10V	mV/bar	± 20
	1000bar/10V	mV/bar	± 10
	2000bar/10V	mV/bar	± 5
Accuracy		%	± 1
Offset (output)		mV	$< \pm 15$
Drift (20°C)		pC/s	< 0.03
Reset/Operate transition		pC	< 2
Output noise		mV	< 15
Frequency range		mVpp	< 20
		kHz	0...10

Voltage Measurement

Number of voltage channels (extendable in pairs of 2)			2 ... 16
Zero voltage (0 Volt)		V	0
Input signal		V	-40 ... 40
Output signal		digital	14 bit
Sensitivity			0.25

System properties

A/D sampling rate per channel			kHz 16
Sampling rates (4 fixed frequencies)		kHz	0.25/0.5/1/2
Reaction time from analog to digital output		μ s	500
Minimum reaction time with filters switched off		μ s	62.5
Automatic EMC filter (spectral line width)		μ s	125
Reaction time from digital input to digital output		ns	31.25
Start synchronizing time after trigger		μ s	500
Synchronizing delay between 64 channels		ns	125

Monitoring Functions

The connected measuring signals can be monitored in real time as absolute values as well as in between a monitoring window by setting one of the following functions. The reaction time for these functions is 500 μ s (= 0.5 Milliseconds). Settings are made via webbrowser.

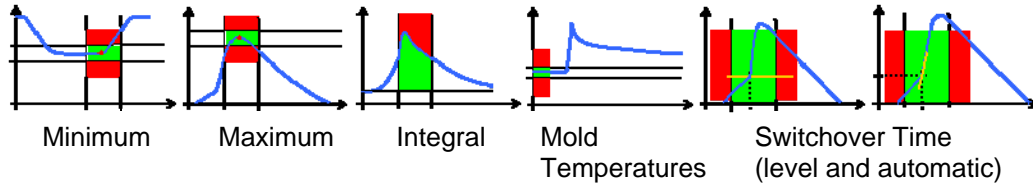

Real Time Behaviour (Examples: Maximum Value)

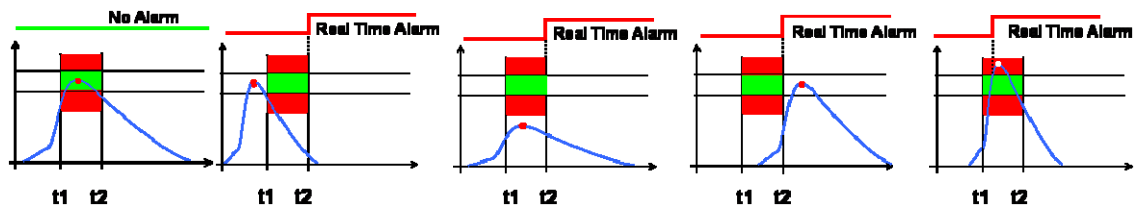

Possible Switchover Methods

Automatic Cavity Temperature

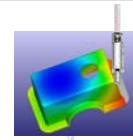
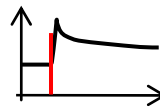

By Level e.g. Cavity Pressure

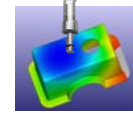

Intelligent First / Last Signal

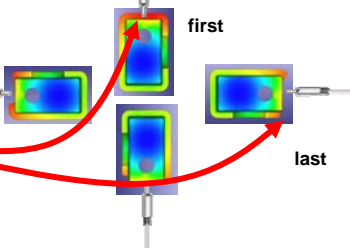
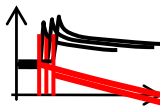

Automatic Determination of Monitoring Limits („Master Key“)

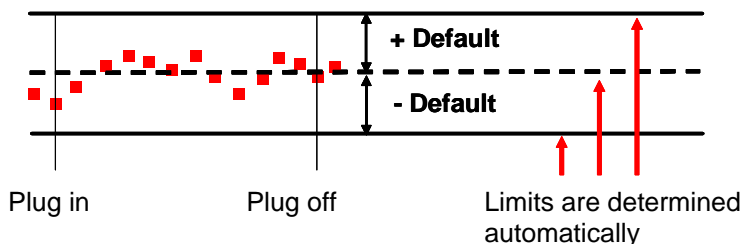

Dimensions

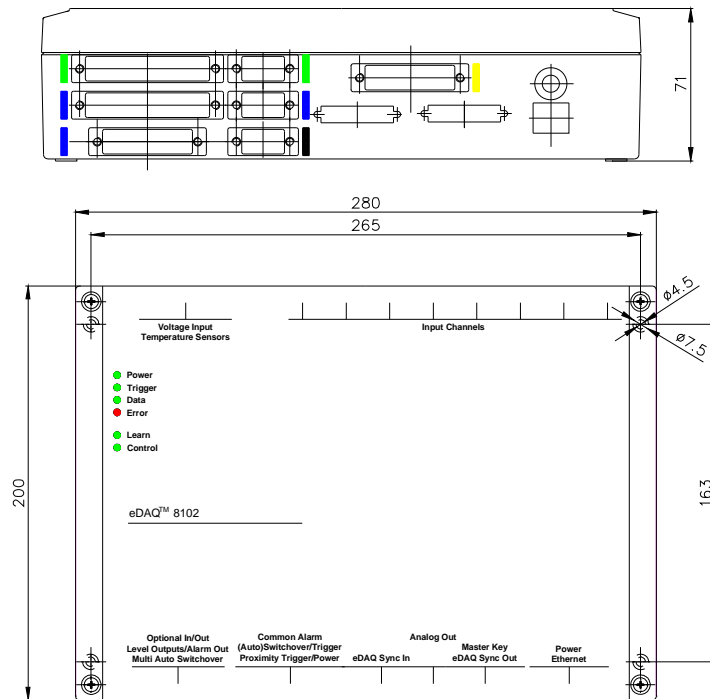

Interfacing Options

The unit can be equipped with 2-channel amplifier cards which measure piezoelectric charges, temperature signals or voltages. The kind of measuring channels as well as the kind of connectors are selected by the user when ordering.

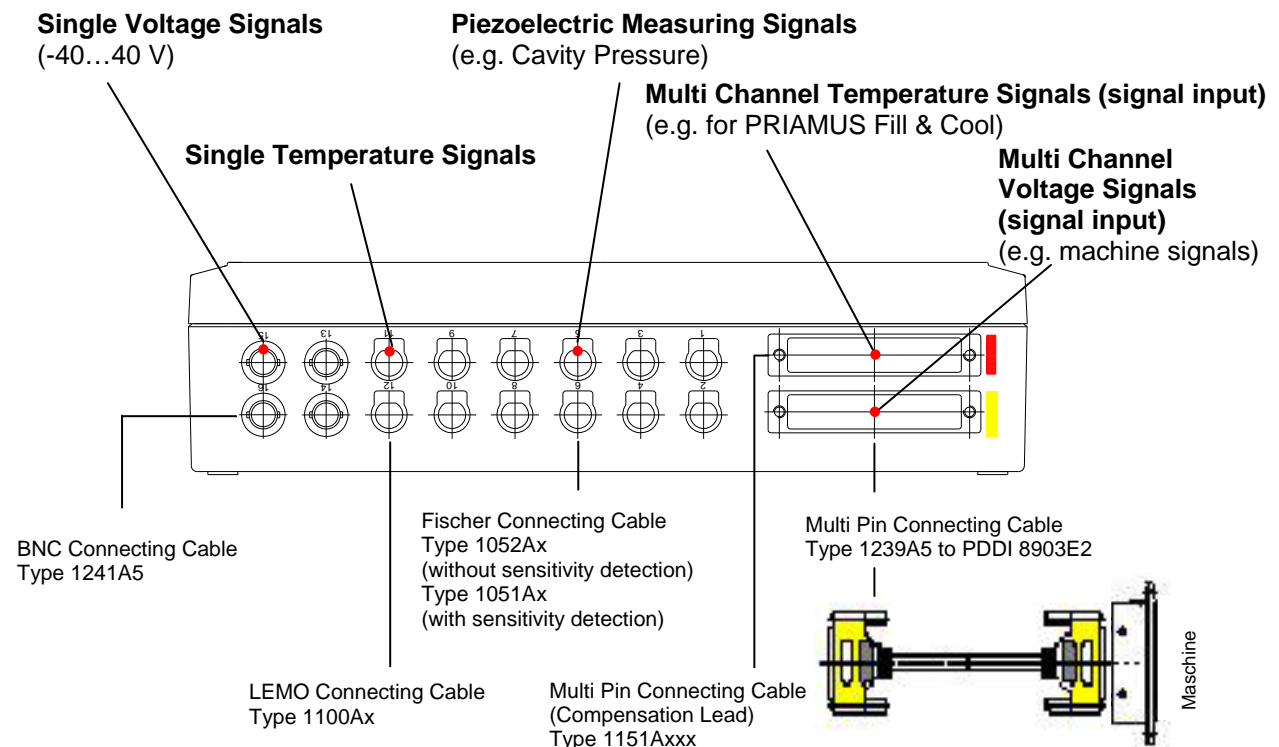

Power Supply

Power is supplied either by an external power supply unit (Type 9002A) or directly e.g. from an injection molding machine together with the power supply unit type 9005A. For this purpose the PRIAMUS Digital Data Interface Type 8903D1 is used.

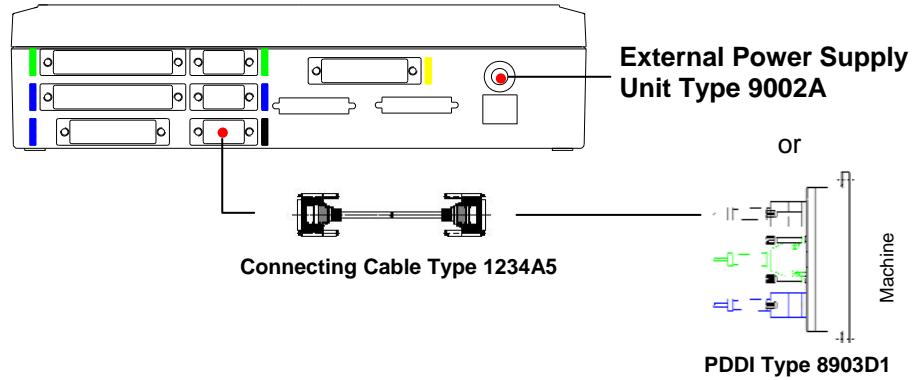

Trigger / Start of the Measurement

The measurement is started automatically either by a machine signal (e.g. start injection via PDDI) or with a proximity switch (Type 9001A) which is attached to the mold temporarily.

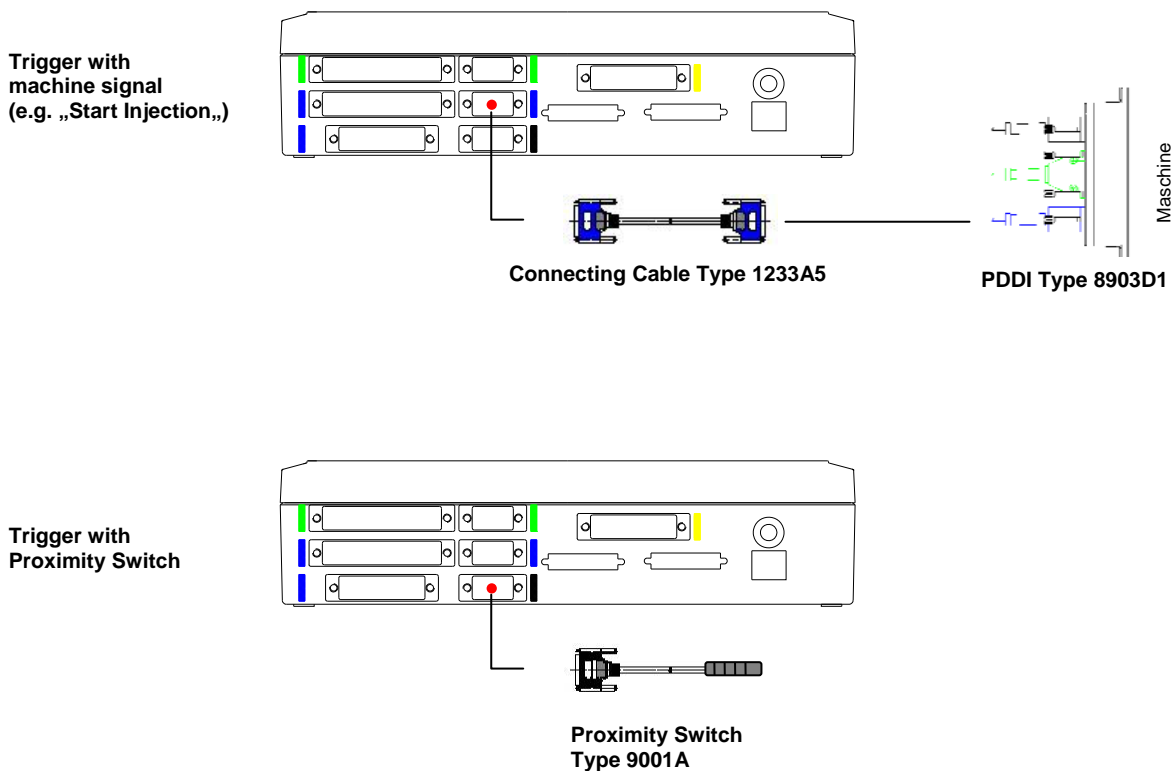

Switchover to Holding Pressure („Auto-Switchover“ and „Switchover“)

The eDAQ™ system provides real time output switching signals for process control. Switchover can be triggered either automatically (“Auto Switchover”) through a temperature increase or decrease (→ automatic switchover to holding pressure) or by a programmed level. In case of injection molding usually there is only one switchover signal required to holding pressure. For this reason each of these functions are connected to separate output pins. These external switchover signals are interfaced to the machine via PDDI Type 8903D1.

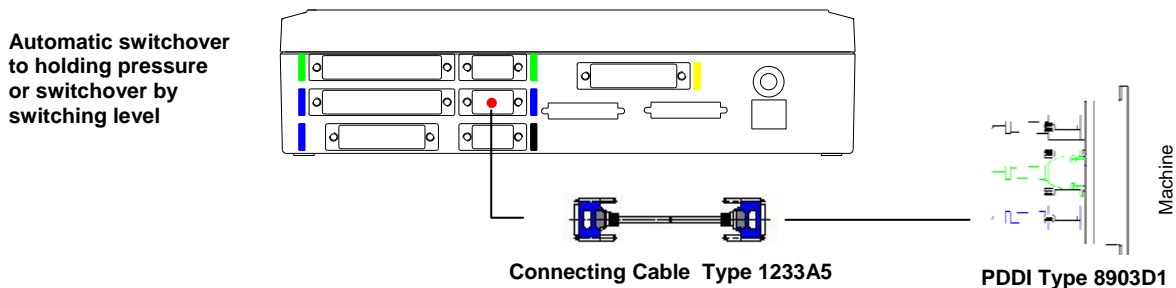

Automatic Switching Signals for Individual Process Control („Multi Auto-Switchover“)

For each channel of the eDAQ™ system one real time switching signal is provided which automatically gets triggered when the plastic melt reaches the cavity temperature sensor. This method can be used for thermoplastics, for thermosets as well as for elastomers. The single switching signals can be delayed individually and the active switching time can be set individually for each signal. These switching signals are used for example for the automatic control of sequential molding applications or for the automatic opening and closing of valve gates e.g. for silicone molding (LSR).

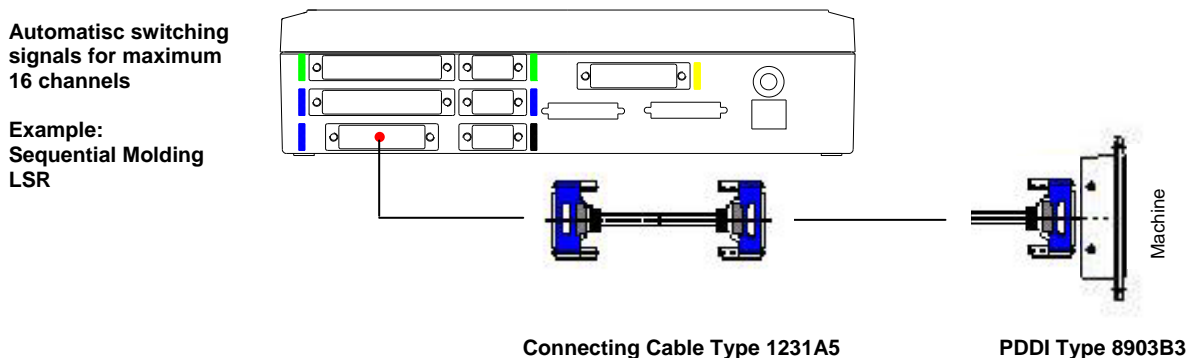

Individual Switching Signals and Alarm Outputs

Each single measuring channel (Pressure or Force / Temperature / Voltage) can be switched by a programmable switching level. Every single switching signal can be individually delayed and the active switching time can be set. Besides injection molding numerous applications for this technique can be found in process technology.

On the same interface 16 alarm output signals are provided which can be used for process monitoring. For this reason it is possible for example not to reject all molded parts of a 16 cavity mold but only those ones which are actually out of tolerance.

Individual switching signals and alarm signals for maximum 16 channels

Example:
Control of valves
Control of gas pressure applications
Process monitoring

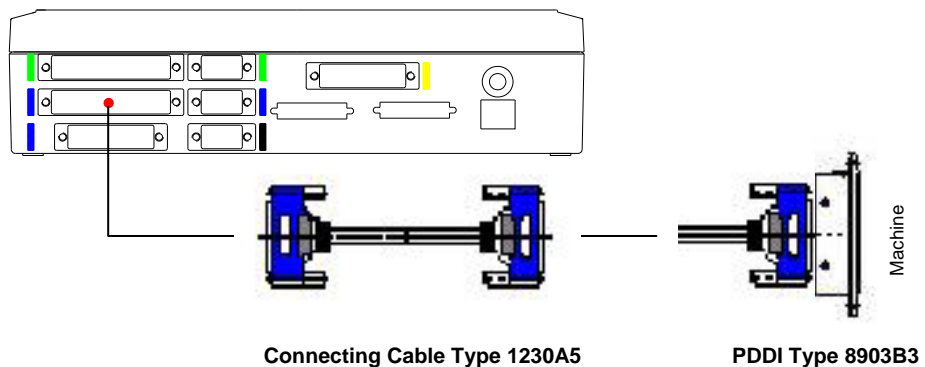

General Process Monitoring: Common Alarm Signals

All monitoring functions as well as the Auto Switchover function (e.g. for automatic switchover to holding pressure) and the Switchover function (e.g. for the control of valves or nozzles) can be monitored by so called "Common Alarm Signals".

As soon as any of the defined monitoring functions is out of limits an alarm signal will be sent to these outputs. This complies with the simple case of a good part / bad part reject gate ("part containment"). The PDDI Type 8903D1 is used to interface the signals to the machine respectively to the peripherals ("robot").

Monitoring through „Common Alarm“ signals

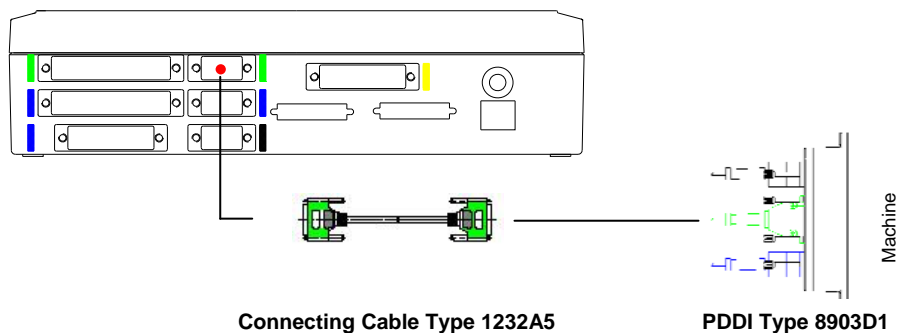

Option: Additional Alarm Output Signals and Digital Input and Output Signals

For complex process monitoring solutions 16 additional alarm signals are provided as an option. The digital inputs and outputs are freely programmable.

16 additional alarm signals
16 digital input signals
2 digital output signals

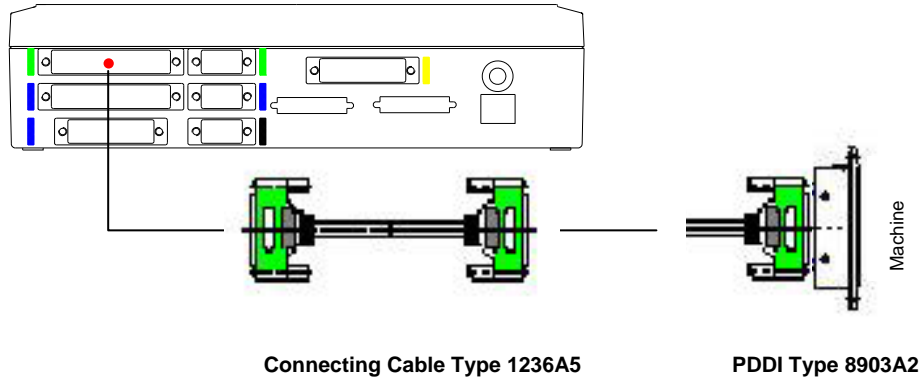

Digital Outputs for PRIAMUS control systems

In addition, 5 digital outputs are available for specific monitoring functions of the PRIAMUS control systems such as PRIAMUS Fill & Cool.

5 Digital outputs
Example:
PRIAMUS Fill & Cool

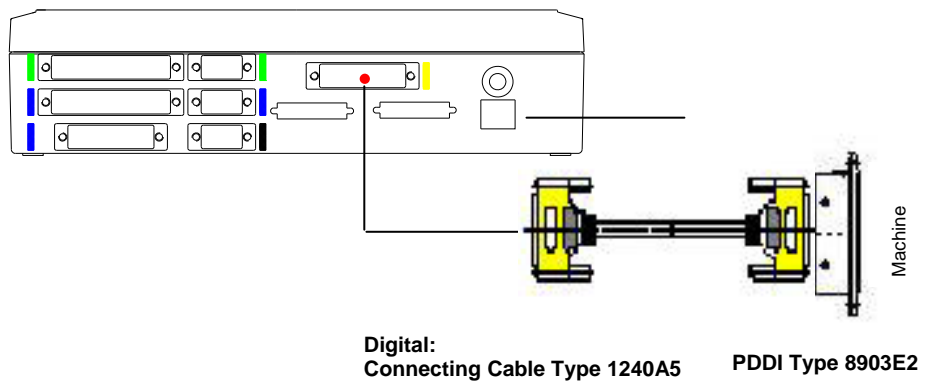

Digital and Analog Output Signals

For further data processing the eDAQ™ system provides the maximum 16 measuring signals as digital signals via Ethernet interface as well as analog signals (0...10 V).

Digital measuring signals via Ethernet

16 analog measuring signals

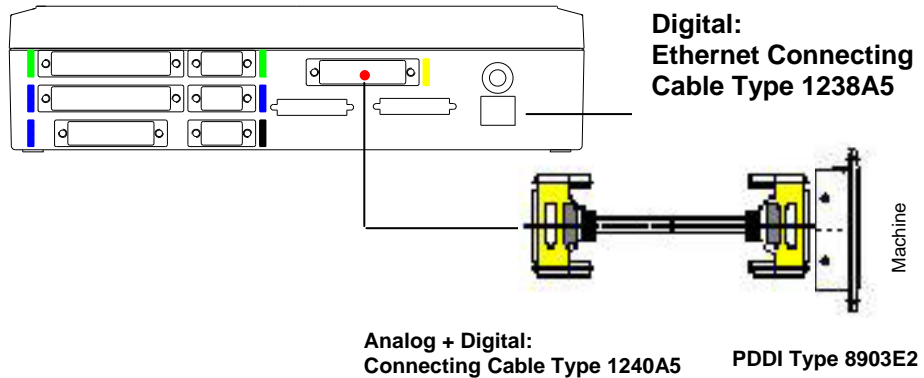

Synchronizing of Multiple Units

In case of more than 16 measuring channels (maximum 128) up to 8 eDAQ™ units can be operated and synchronized simultaneously.

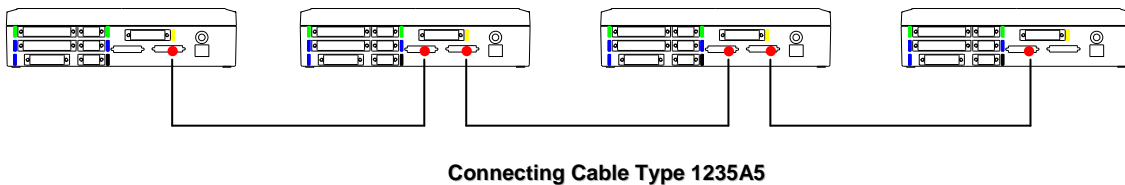

Webbrowser Setup

The setup of the device is made either directly by the application software (e.g. MoMo) or in case of stand-alone operation by a webbrowser.
This webbrowser can be downloaded to a laptop via Ethernet interface.

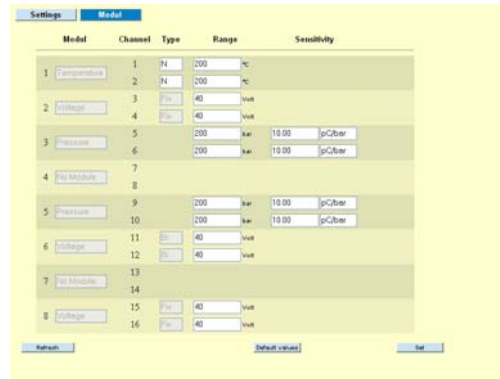

Log In Menu

Select:

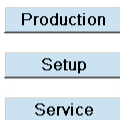

Password:



Automatic Module Detection

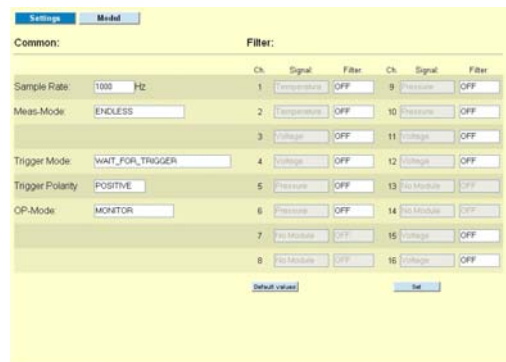

Password Protected User Levels

Universal Data Acquisition



Versatile Process Monitoring Functions

Overview Connecting Cables

In order to make connections as simple as possible for the user PRIAMUS provides a number of analog and digital interfaces which are mounted to the control cabinet.

PRIAMUS Digital Data Interface (PDDI) Type 8903D1: 3 x D-Sub 9-pin
 PRIAMUS Digital (Analog) Data Interface (PDDI) Type 8903E2: 2 x D-Sub 37-pin, 1 x D-Sub 25-pin
 PRIAMUS Digital Data Interface (PDDI) Type 8903B3: 1 x D-Sub 37-pin, 1 x D-Sub 25-pin



Example: PDDI mounted to control cabinet

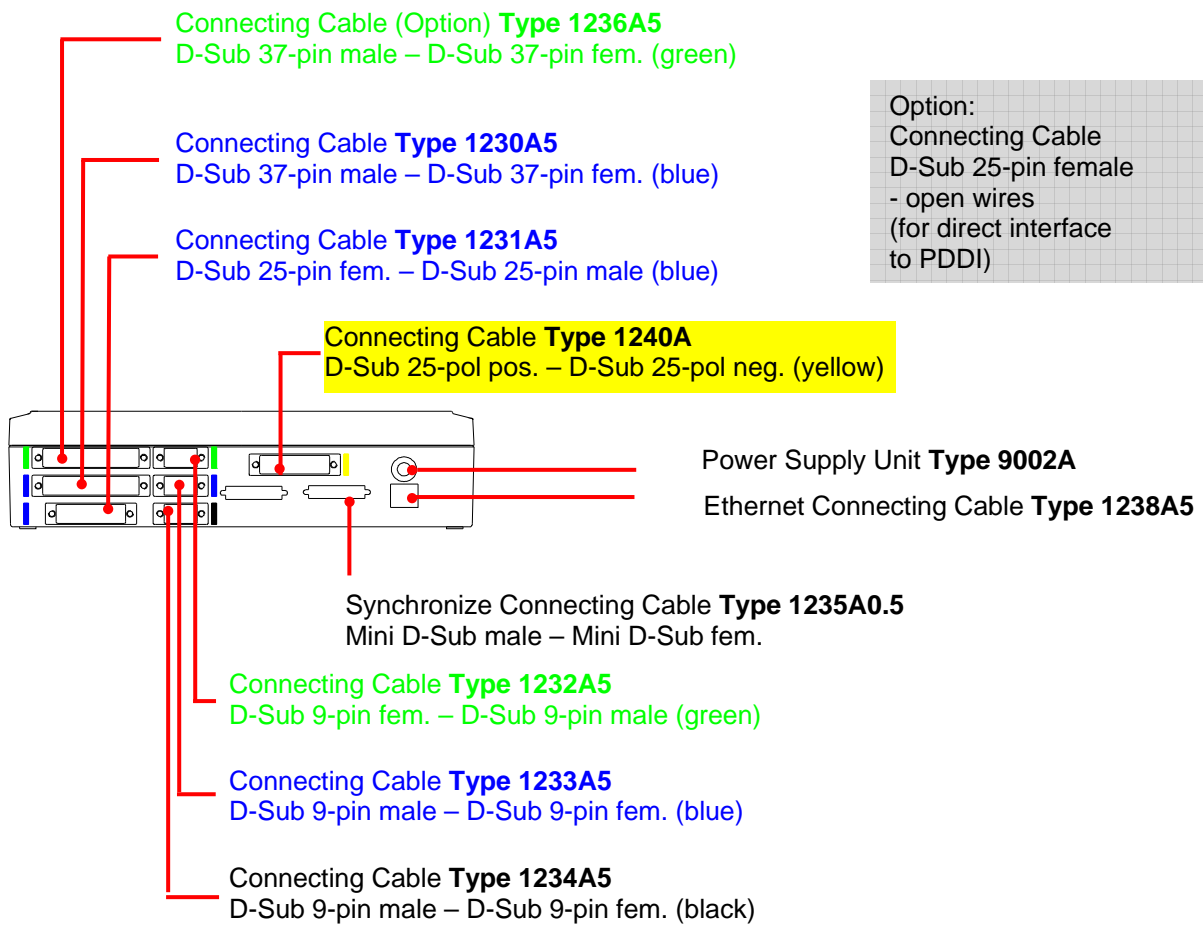



Order Codes

		Temperature	T Connector	Pressure/Force	Voltage	Option: Alarm	Option:Synch
Order Code	8102C	X	X	X	X	X	X
Position	1-5	6	7	8	9	10	11

Position	Description	Options
1-5	Basic Unit	8102B
6	Number of temperature modules	0...8 (1 module = 2 channels)
7	Cavity temperature signals to LEMO or D-Sub 37-pin connector	0 = No cavity temperature signal D = Cavity temperature signal to D-Sub L = Cavity temperature signal to LEMO
8	Number of pressure modules	0...8 (1 module = 2 channels)
9	Number of voltage modules	0...8 (1 module = 2 channels)
10	Option: Additional alarm outputs	A
11	Option: Synchronizing interface For operation of multiple devices	S

- Temperature modules are always installed in the first slots
- Pressure modules are always installed in the following slots
- Voltage modules are always installed in the last slots available
- All modules provide 2 measuring channels

Example: eDAQ™ for 8 cavity temperature signals, for 4 cavity pressure signals and for 4 machine signals (total = 16 channels). The temperature signals should be connected via D-Sub connector (e.g. for the PRIAMUS Fill-System). No further options.

Order Code	8102C	4	D	2	2		
-------------------	--------------	----------	----------	----------	----------	--	--

Scope of delivery

- Master Key type 1185A
- Ethernet-connecting cable type 1238A5

Accessories

- Power supply unit type 9002A
- Power supply unit type 9005A for switch cabinet mounting
- Proximity switch (trigger) Typ 9001A
- Trigger cable Type 1220A5
- Connecting cable types 1051A2 / 1051A5 / 1051A10 for PRIASED™ cavity pressure sensors
- Connecting cable types 1052A2 / 1052A5 / 1052A10 for conventional cavity pressure sensors
- Connecting cable (metal braided) types 1065A2 / 1065A5 / 1065A10 for PRIASED™ cavity pressure sensors
- Connecting cable (metal braided) types 1066A2 / 1066A5 / 1066A10 for conventional cavity pressure sensors
- Connecting cable types 1151A... for cavity temperature sensors with multi pin connector
- Connecting cable types 1100A2 / 1100A5 / 1100A10 for cavity temperature sensors with LEMO-Connector (type 4002A)
- Sensor Tester type 8950A
- Connecting cable types 1230A5, 1231A5, 1232A5, 1233A5, 1234A5, 1235A5, 1236A5, 1237A5, 1239A5, 1240A5, 1241A5
- PDDI type 8903D1
- PDDI type 8903E2
- PDDI type 8903B3